

technical note

T1 Basics

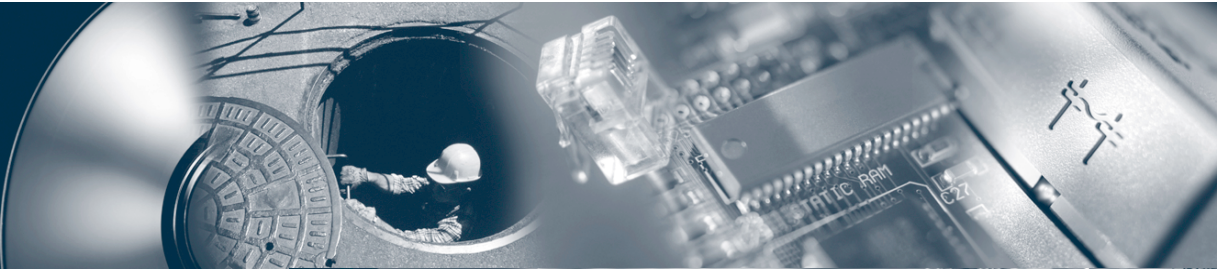

T1 Basics



When a technology gains rapid acceptance, it often reaches buzzword status before the details are commonly understood. So it is with T1: although it is an important part of many communications networks, many of us are still trying to learn the fundamentals.

The objective of this technical note, then, is to provide the reader with basic information about T1. It starts with a definition and brief history, evolves to describe how the technology actually works, and concludes with a summary of the benefits and techniques of testing T1 networks.

A rudimentary knowledge of electronics as it applies to telephony is assumed.

T1 is a digital communications link that enables the transmission of voice, data, and video signals at the rate of 1.544 million bits per second (Mbps). Introduced in the 1960s, it was initially used by telephone companies who wished to reduce the number of telephone cables in large metropolitan areas.

In its early days, the expense of installing T1 made the technology cost-prohibitive for many end users. In fact, the primary user of T1 services outside of the telephone companies was the federal government. But in the early 1980s, the service was retariffed so that substantial savings could be realized with the purchase of large amounts of bandwidth. After retariffing, the demand for T1 increased substantially.

Why is T1 in Demand?

The current demand for T1 services can be linked to a number of tangible benefits.

Simplification

T1 simplifies the task of networking different types of communications equipment. To illustrate, **Figure 1**¹ shows what your company's communications network might look like without T1.

Figure 1 shows that telephone, facsimile, and computer applications would all require separate lines. Typically, voice and low-speed data applications are serviced by analog lines, while high-speed data applications are serviced by digital facilities.

Figure 2 below depicts the same network with a T1 link installed.

T1 links carry both voice and data on a single digital communications link. By reducing the number of lines needed to carry information, the task of managing many different networks is simplified. One example of equipment that merges these signals is the T1 multiplexer and is described in more detail later in this technical note.

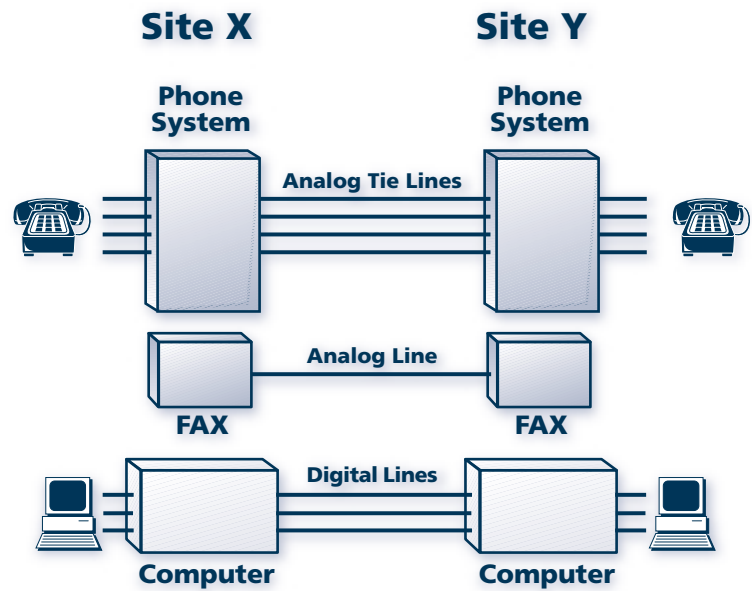

Figure 1:
A communications network without T1

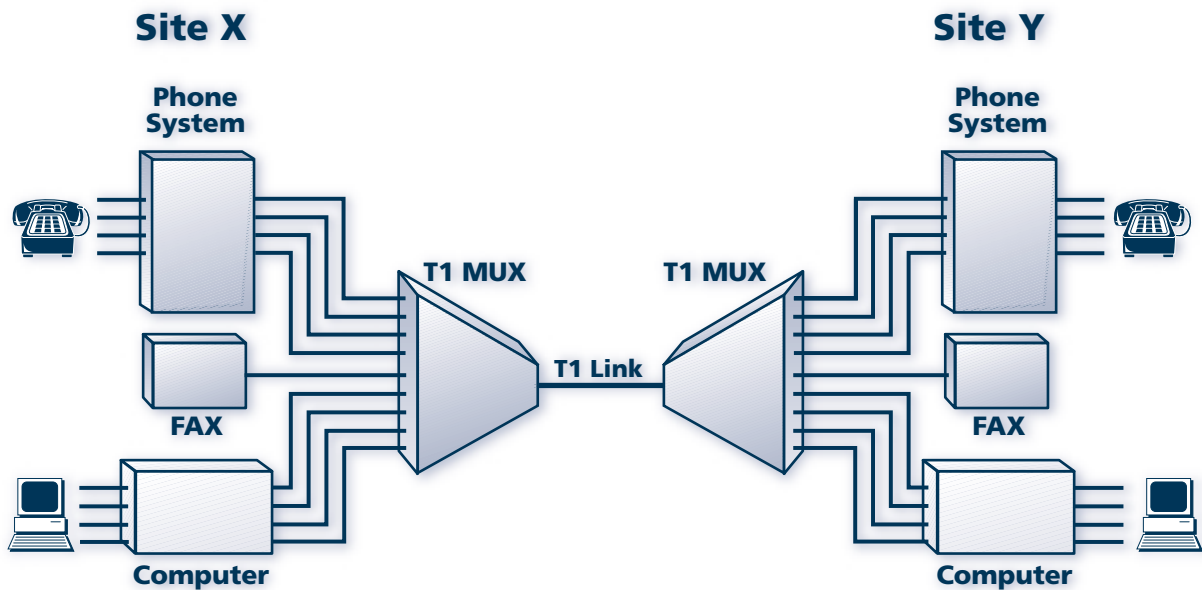

Figure 2:
A communications network with T1

¹Figures in this technical note are derived from Flanagan, William A., *The Teleconnect Guide to T1 Networking*, Telecom Library, 1986.

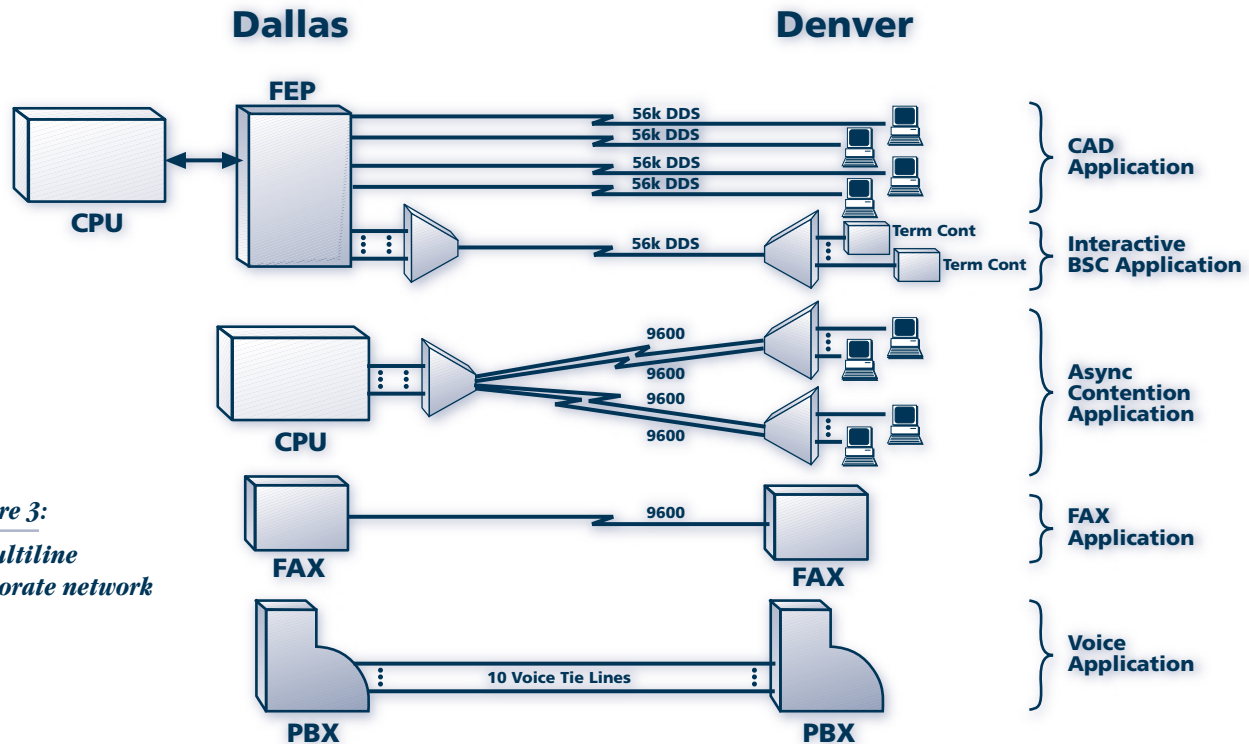

Figure 3:
A multiline corporate network

Economy

T1 is extremely economical for organizations with high traffic volumes. As an example, **Figure 3** depicts a multiline corporate network between Dallas and Denver.

In 1985, the monthly operating costs of the network shown in **Figure 3** were approximately \$27,000.

Using a T1 link to eliminate the expense of separate lines as shown in **Figure 4** on the next page, monthly operating costs decreased by approximately \$7,000 per month, or \$85,000 per year. And since 1985, the tariffs have moved even more favorably toward T1 usage. The yearly savings on operating costs for this corporate network have since increased to over \$150,000.²

In addition to cost savings, the T1 model shown in **Figure 4** provides plenty of bandwidth for future expansion *with no increased transmission costs*.

Signal Quality

T1 also provides a signal which is consistently superior in quality to that provided by analog facilities. Analog circuits amplify noise and distortion to levels that can

impair voice and severely degrade data service. But T1 regenerates the original signal without the noise and distortion at various points along the links.

How T1 Works – Making Voice and Data Compatible

Many benefits of T1 are attributable to the fact that voice and data transmitted over a single digital communications link. Since computer data consists of ones and zeros (the symbols of the binary system), it is already compatible with T1's digital format. However, because voice signals are actually complex analog waveforms, they must be digitized to achieve compatibility with T1.

Pulse Code Modulation (PCM)

The most common method of digitizing analog voice signals is a technique called PCM. It is a sampling process that compresses a voice conversation into a 64 kbps standard rate known as digital signal-level zero (DS0).

PCM is actually a two-step technique. In the first step, the incoming analog signal is sampled 8,000 times per second, a rate sufficient to adequately represent voice information. These sample values are then converted to pulses using a process known as pulse amplitude modulation (PAM), as shown in **Figure 5**.

In the second step, the height of each pulse is assigned an equivalent eight-bit binary value (see **Figure 6**). The resulting output is a digital representation of the pulse and, by extension, the sampled analog waveform.

The 64 kbps DS0 rate is obtained by multiplying the number of samplings per second (8,000) by the number of bits in each sample (eight).

²Flanagan, William A., *The Teleconnect Guide to T1 Networking*, Telecom Library, 1986.

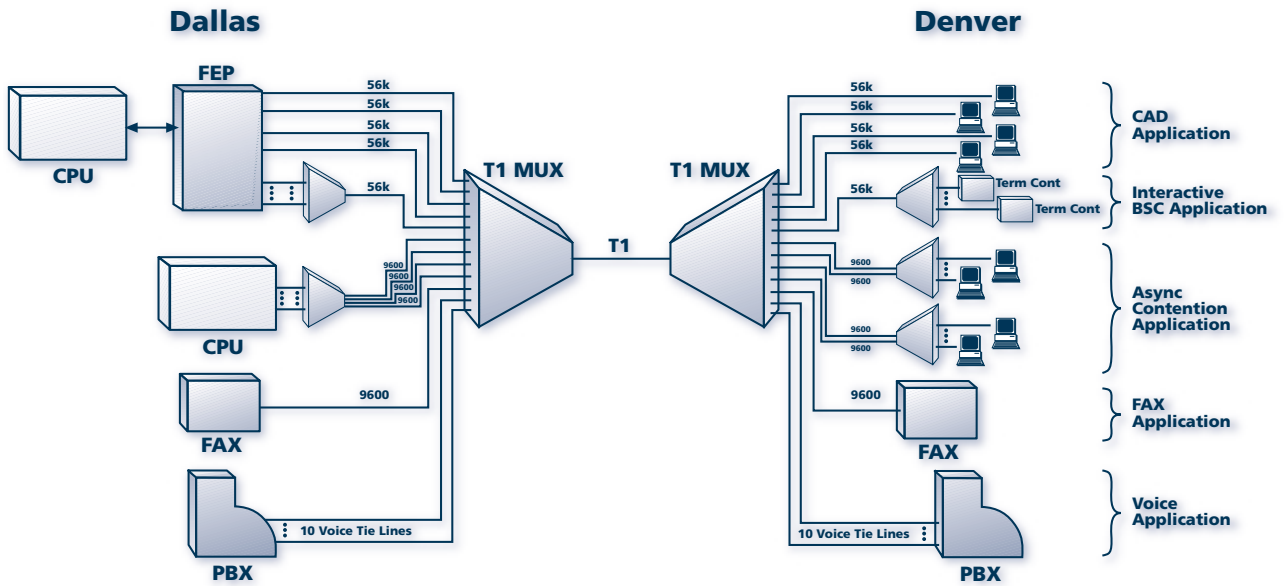

Figure 4:
A multiline corporate network with T1

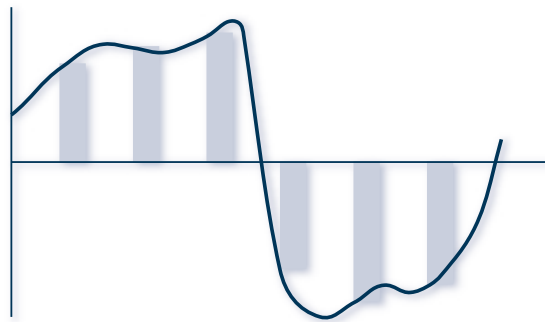
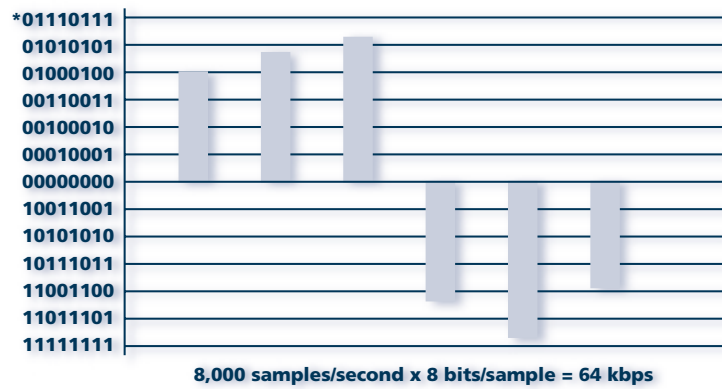

Figure 5:
Pulse amplitude modulation

Figure 6:
Assigning binary values to pulses



*For example only, not actual bit values

Time Division Multiplexing (TDM)

Once digitized, voice and/or data signals from many sources can be combined (i.e., multiplexed) and transmitted over a single T1 link. This process is made possible by a technique called TDM.

TDM divides the T1 link into 24 discrete 64 kbps timeslots. An identical number of DS0 signals (representing 24 separate voice and/or data calls) is assigned to each timeslot for transmission within the link as shown in *Figure 7*.

In addition to being critical operational techniques, PCM and TDM are also key to understanding the basic T1 rate of 1.544 Mbps.

1.544 Mbps Explained Signal Regeneration

In T1, the eight-bit digital samples created in the PCM step (for voice traffic only) are grouped into the 24 discrete DS0 timeslots created by TDM. Each group of 24 timeslots is called a T1 frame (see *Figure 8*). Since each timeslot contains eight bits, the number of information bits within each frame totals 192 (24 x 8). Additionally, a 193rd bit is added to mark the end of one frame and the beginning of the next. Appropriately enough, this added bit is called the framing bit.

Since the DS0 signals are sampled 8,000 times per second, it means that 8,000 192-bit information frames are created during that period. Total: 1.536 Mbps. At 8,000 samples per second, framing bits are created at the rate of 8 kbps. Result: a single 1.544 Mbps signal known as digital signal-level one (DS1). See *Table 1* on how to calculate the 1.544 Mbps rate.

Any newly created DS1 signal begins strongly, but degrades (i.e., attenuates) as it progresses along the T1 link. Such attenuation is usually the result of line noise caused by interference from other electrical sources. To compensate for these negative effects, devices called regenerative repeaters sample and recreate the original signal at periodic intervals along the link as shown in *Figure 9*.

Since the digital signal consists of only two basic values (one and zero), recreating it is not a complicated matter. In simple terms, a regenerative repeater samples the signal input, determines if the input represents a one or a zero, and recreates each value accordingly. Since line noise deviates from the standard format of the DS1 signal, it is discarded. In this way, a regenerative repeater produces a “clean” replica of the original signal.

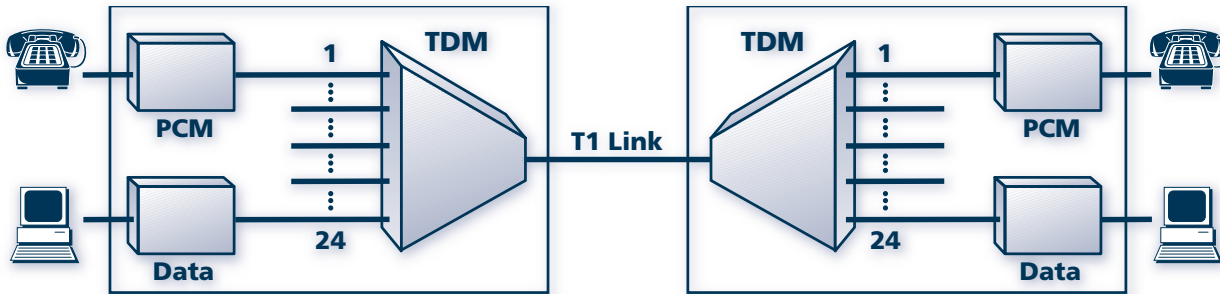

Figure 7:
Time division multiplexing

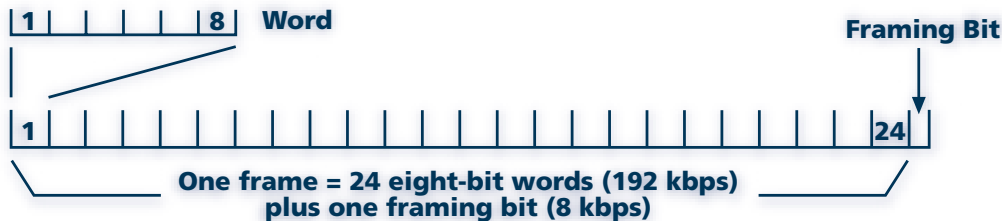

Figure 8:
A T1 frame

The number of regenerative repeaters that may be required along the path of the T1 link varies with the type of transmission media used. For example, copper wire (a common short-haul metallic medium) is highly prone to signal attenuation: thus, repeaters are normally required at 6,000-foot intervals. By contrast, fiber optic cable is a long-haul medium with low potential for attenuation; as such, repeaters are spaced at 30-mile intervals. **Table 2** explains how T1 works.

Appendix A on page 18 describes the characteristics of a wide variety of T1 transmission media in detail.

Step	What Happens	Calculation
1	The eight-bit digital samples created by PCM (for voice signals only) are grouped into the 24 discrete timeslots created by TDM. Each group of 24 timeslots is called a T1 frame.	$\begin{array}{r} 24 \text{ samples} \\ \times 8 \text{ bits per sample} \\ \hline 192 \text{ information bits per frame} \end{array}$
2	A framing bit is added to mark the end of one frame and the beginning of the next.	$\begin{array}{r} 192 \text{ information bits} \\ + 1 \text{ framing bit} \\ \hline 193 \text{ total bits per frame} \end{array}$
3	T1 frames are transmitted at the rate of 8,000 per second.	$\begin{array}{r} 8,000 \text{ samples} \\ \times 193 \text{ total bits} \\ \hline 1,544,000 \text{ bits per second (1.544 Mbps)} \end{array}$

Table 1:
Calculating the 1.544 Mbps T1 rate

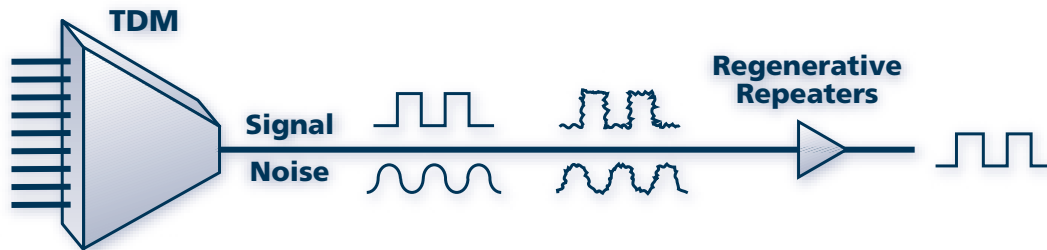

Figure 9:
Signal regeneration

Process	What Happens
Pulse Code Modulation (PCM)	<ol style="list-style-type: none"> 1. Samples the incoming analog signals 8,000 times per second and converts the sampled values to pulses. 2. Assigns the height of each pulse an equivalent eight-bit digital value. 3. Creates a 64 kbps DS0 signal (8,000 samples per second multiplied by eight bits).
Time Division Multiplexing (TDM)	Combines 24 DS0 signals to create a single 1.544 Mbps signal (DS1)
Signal Regeneration	Recreates the 1.544 Mbps signal at prescribed intervals along the transmission path.

Table 2:
How T1 works

The DS1 Signal Format

The DS1 signal is transmitted on the T1 link in a binary format (ones and zeros). The ability to recognize the proper format of the DS1 signal is why regenerative repeaters can distinguish valid input from line noise. As an example, **Figure 10** depicts a format which is very commonly used over metallic transmission media (e.g., twisted pair cable, copper wire, etc.): alternate mark inversion (AMI).

In the AMI signaling format, the binary value of one is represented by a square wave (i.e., pulse); the binary value of zero is represented by a straight line (i.e., the absence of a pulse).

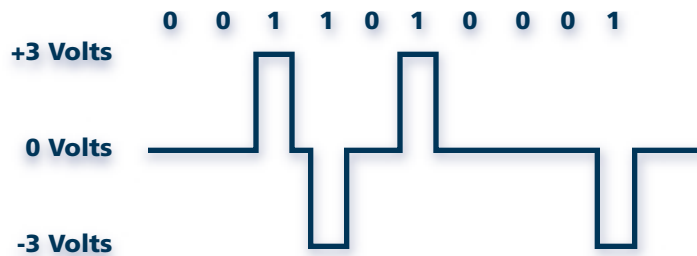

Figure 10:
Alternate mark inversion

Each pulse alternates between positive and negative polarity, making the signal bipolar in format.

The primary advantage of the bipolar format is that it allows the DS1 signal to travel twice as far on a pair of copper wires. Another advantage of the bipolar format is its ability to offer a built-in method of error detection. When consecutive pulses of the same polarity are detected, it constitutes a bipolar violation (BPV). BPVs indicate that signal input has been disrupted due to defective equipment or poor environmental conditions (e.g., storms).

B8ZS, Signal Timing, and Ones Density

To correctly identify DS1 input, the regenerative repeater must know when to sample the bipolar signal to determine whether a one or a zero is being transmitted at any given time. To ensure proper sampling, the repeater relies on a timing method that uses the binary pulses (i.e., ones) to maintain synchronization with the network equipment that is transmitting the DS1 signal.

Since pulses are critical to maintaining proper signal timing, all DS1 signals are required to meet specific ones density standards. These standards require that at least one pulse be transmitted within any eight-bit sequence (i.e., 12.5% ones density). Further, since long strings of consecutive zeros between digital values can also hinder signal timing, ones density standards prohibit the transmission of more than 15 zeros in succession.

Success in meeting ones density requirements can vary based on application. For example, since the size and content of the bit patterns that represent human speech are consistent, acceptable ones density in voice applications is a virtual certainty. But since computer data is highly variable in size and content, conformance to ones density standards cannot always be guaranteed. This technical problem is why a coding technique known as bipolar with 8-zero substitution (B8ZS) has gained in popularity.

B8ZS uses intentional BPVs to break up long strings of zeros, allowing their transmission through the T1 link without violating the ones density standard.

Figure 11 on the next page shows how B8ZS works.

With B8ZS, network equipment replaces any string of eight consecutive zeros with two intentional BPVs before the DS1 signal is transmitted over the T1 link: the first BPV replaces the fourth zero; the second replaces the fifth and seventh zeros. Additionally, the eighth zero bit, which normally would be coded as a zero, is assigned a pulse value.

Using this format, the DS1 signal can pass through the repeaters on the T1 link with an acceptable level of pulse density. When the signal arrives at the receiving network equipment, the pattern shown in **Figure 11** is recognized as the B8ZS substitute for eight consecutive zeros; the equipment then replaces the intentional BPVs with their zero values.

DS1 Framing

The bits in the 1.544 Mbps DS1 signal are meaningless unless they are organized in an orderly, understandable way. Framing provides this organization (see **Table 3**).

A frame contains one sample (byte) from each of the DS1's 24 timeslots. Framing bits separate the frames and indicate the order of information arriving at the receiving equipment.

Although most standard T1 networks use framing, the pattern of the frame can vary depending on the sophistication of the equipment that is sending and receiving the DS1 signal. The sections that follow describe typical DS1 framing patterns starting with the most simple: the D1 frame.

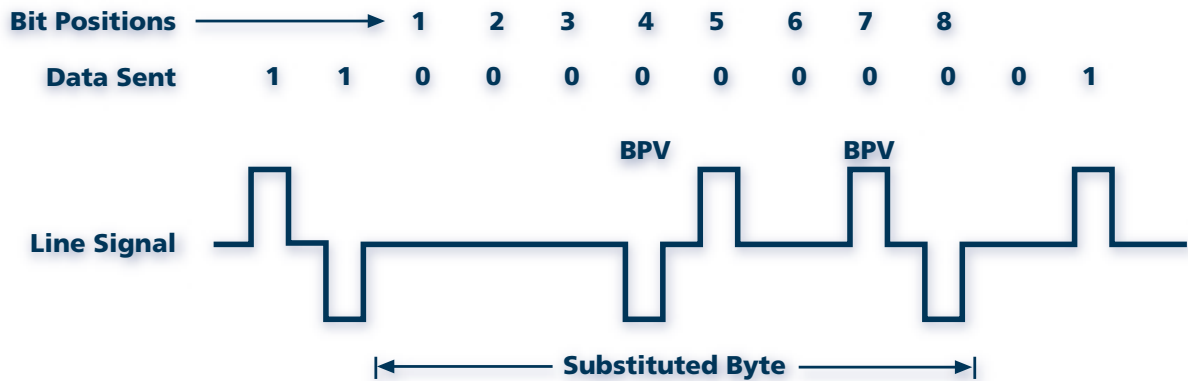

Figure 11:
Bipolar with 8-zero substitution

Bit(s)	Contain(s)
One to seven of each eight-bit word	The customer's digitized voice or computer data.
Eight of each eight-bit word	Signaling information that controls call set up and routing.
193 of each frame	The boundary between the end of one frame and the beginning of the next.

Table 3:
D1 framing organization

The D1 Frame

Shown in **Figure 12**, D1 was the first framing pattern to be used in T1 transmission.

A D1 frame contains 24 timeslots, each carrying an eight-bit word, with one bit serving as a framing boundary ($24 \times 8 + 1 = 193$). In the D1 framing

pattern, bits one to seven of each eight-bit word are reserved for customer information (e.g., digitized voice), bit eight of each word is reserved for signaling information (i.e., call set up and routing), and bit 193 serves as the boundary between the end of one frame and the beginning of the next.

The D1 framing format can certainly simplify framing and signaling management for T1 networks with older, unsophisticated equipment. Unfortunately, D1 is also very inefficient: reserving one bit in every eight-bit word for signaling can degrade a voice signal to levels below toll quality.

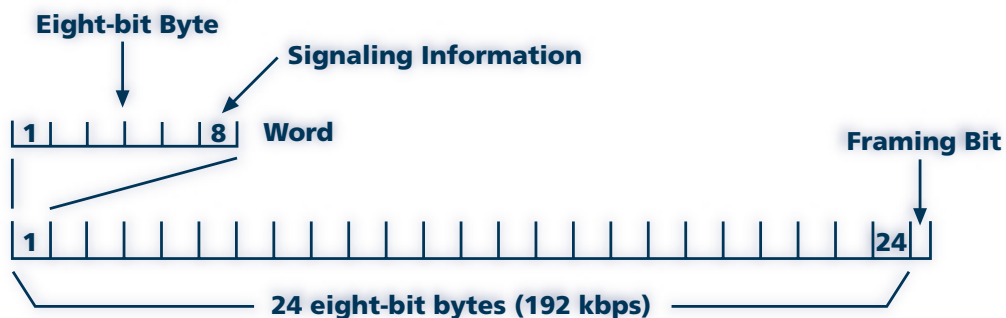

Figure 12:
D1 framing pattern

Fortunately, the sophistication level of the equipment in T1 networks has increased dramatically. As such, it is now possible for many frames to share the same framing and signaling information. Thus, the chance to free more bits for customer information (thereby improving signal quality) inspired the development of the superframe (SF) as shown in *Figure 13*.

A SF is made up of 12 individual frames, with the 193rd bit in each frame used as a control bit. When combined, these control bits form a 12-digit word (100011011100) that provides frame and signal management.

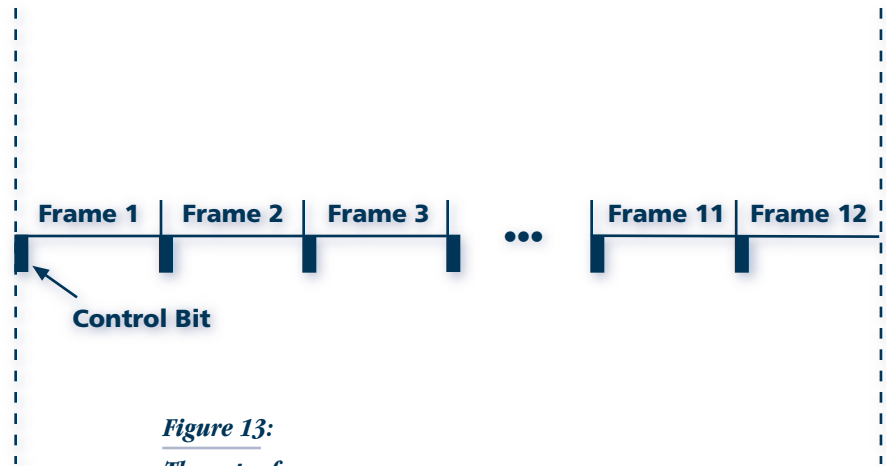

Figure 13:
The superframe

D4 Framing

In today's public switched telephone network, the pattern commonly used to organize the SF is the D4 framing pattern.

In D4 framing, the odd bits in the control word (called terminal frame or f_t bits: 1X0X1X0X1X0X) mark frame and SF boundaries so that the receiving equipment can correctly process the customer's voice or data information.

The even bits in the control word (called signaling frame or f_s bits: X0X0X1X1X1X0) identify the frames which carry signaling information.

Using the robbed bit signaling, the least significant (8th) bit of the DS0's in the 6th and 12th frames is reserved for signaling information. The steady state of the bit, one or zero, indicates whether the called device is on-hook, off-hook, disconnected, busy, etc.

In summary, D4 framing improved signal quality by freeing more bits for customer information. But the continued emphasis on quality and the evolution of integrated circuit technology have yet enhanced the SF.

In ESF, six control bits are reserved for a cyclic redundancy check (CRC), a method of detecting errors as information is transmitted along the T1 link (2 kbps); 12 bits are reserved as a data link for communication between transmitting and receiving equipment at either side of the T1 link (4 kbps); and six bits are used to manage signaling and framing (2 kbps).

The sections that follow briefly describe the ESF's CRC and data link capabilities.

Frames with signaling information are marked by changes in the bit pattern. For example, control bits 2 and 4 contain zeros; since control bit 6 is coded as a one, it means that the 6th frame contains signaling information. Further, control bits 8 and 10 contain ones; since control bit 12 is coded as a zero, it means that the 12th frame also contains signaling information.

To enable the sharing of signaling bits by all 12 frames in the SF, D4 framing uses a process called robbed bit signaling as shown in *Figure 14*.

Extended Superframe (ESF)

Since FCC tariffs require a specific standard of performance, providers of T1 circuits frequently test their links and equipment. But when a link is removed from service for test purposes, it is neither producing revenue nor serving the communications needs of the customer.

The need to obtain a true measure of system performance without disrupting service spurred the development of the ESF format. ESF expands the SF from 12 to 24 193-bit frames (see *Figure 15* on the next page). Like the D4 format, the 193rd bit in each frame is always a control bit.

If ESF were merely D4 framing multiplied by two, then all of its 24 control bits (transmitted at 8 kbps) would be used for frame and signal management. Instead, three-fourths are reserved for the evaluation of circuit performance.

CRC-6

CRC-6 is a six-bit word that detects, with 98.4% accuracy, bit errors (i.e., zeros that should be ones and vice versa) in any block of live data. *Table 4* on the next page depicts how CRC-6 works in *very simple terms*. Consult the References section on page 19 for a list of the publications that describe CRC-6 in greater detail.

The ESF Data Link

ESF reserves 12 bits (transmitted at 4 kbps) as a data link for communication between the transmitting and receiving equipment on each side of the T1 link. Although it can be used for any purpose, one typical use is the transmission of trouble flags such as the yellow alarm signal.

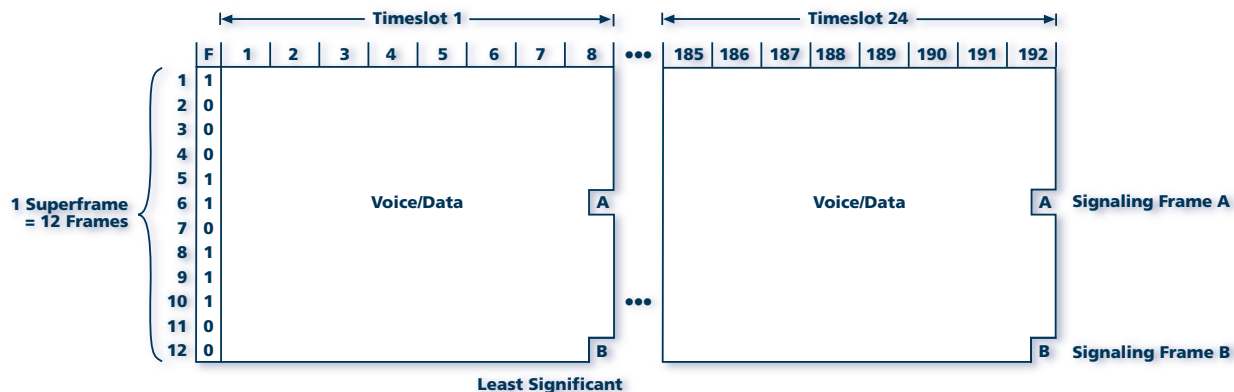

Figure 14:
Robbed bit signaling

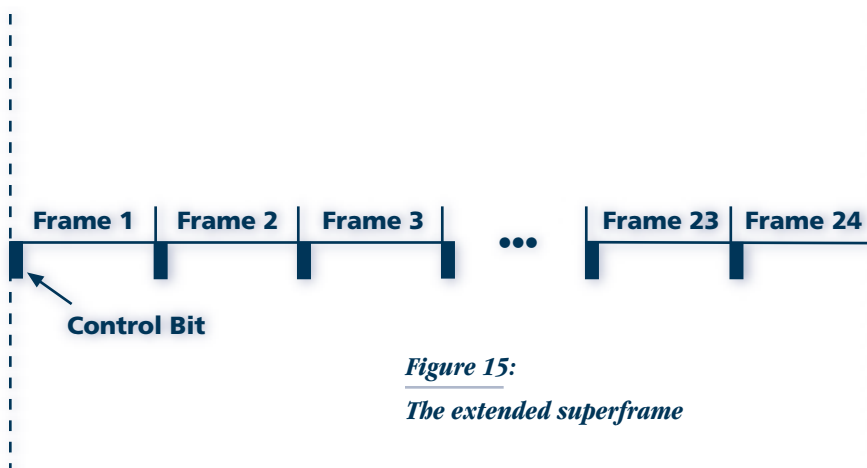

Figure 15:
The extended superframe

Step	Activity
1	The network equipment building the ESF performs a mathematical calculation on the signal to be transmitted across the T1 link. (Control bits are excluded from the calculation.)
2	The signal is transmitted across the T1 link to the receiving equipment. The result of the mathematical calculation is a six-bit word which is sent to the receiving equipment in the six CRC bit positions of the <i>next</i> ESF.
3	The receiving network equipment performs the same mathematical calculation on the customer information, and compares the results with the six-bit word which arrives in the <i>next</i> ESF.
4	If the results match, it is likely that no bit errors have occurred; if the results do not match, it indicates that one or more logic errors have occurred, either in the customer information or in the CRC bits.

Table 4:
How CRC-6 works

The yellow alarm signal is sent by the receiving equipment when synchronization to a transmitted DS1 signal cannot be achieved. The yellow alarm is a continuous 16-bit pattern of eight consecutive ones followed by eight consecutive zeros.

The yellow alarm signal is only one example of how a data link can be used. Consult the References section on page 19 for a list of publications that describe other uses for the data link.

ESF's Enhanced Signaling Capability

In addition to circuit management, ESF also provides enhanced signaling capability. By robbing the eighth bit from the 6th, 12th, 18th, and 24th frames (signaling bits A, B, C, and D, respectively) in the SF, more than 16 signaling states can be represented. Enhanced signaling capability is essential for emerging services such as video, where signaling states beyond the few used in voice service may be required.

T1 Equipment – A Simple T1 Circuit

T1 networks are composed of many different types of equipment, each with a unique role in making the technology work. The equipment that is required in any given T1 network is often based on what the network is designed to do. As an example, a simple private T1 circuit is shown in *Figure 16*.

The circuit is specifically dedicated to connecting the corporate offices in Dallas and Denver (previously shown in Figures 3 and 4 on pages 4 and 5, respectively).

T1 circuits like the ones shown in *Figure 16* contain three general equipment types: terminating equipment, user interface equipment, and transmission equipment.

Terminating equipment primarily serves to build the DS1 signal from voice and data signals of various substrates. (Terminating equipment is where PCM and TDM are

performed.) This type of equipment also “unbuilds” (i.e., demultiplexes) the DS1 and returns voice and data signals to their original substrates at the receiving end. Examples of terminating equipment include channel banks and T1 multiplexers. A description of each type is provided in *Table 5*.

User interface equipment connects terminating equipment with the T1 link, and ensures that both ends of the link send and receive a high-quality DS1 signal. As such, user interface equipment checks for conformance to ones density standards, corrects BPVs, detects yellow alarms, determines AMI or B8ZS signal formatting, and performs CRC-6 calculations (ESF framing only). One common type of user interface equipment that performs all of these functions is the channel service unit (CSU).

Transmission equipment is the physical media used to carry DS1 information. Examples include twisted pair, coaxial, fiber optic cables, and satellite and microwave links. Appendix A on page 18 describes several types of transmission media in detail, including repeater requirements.

A Public T1 Network

Alternatively, the corporate offices in Dallas and Denver can also communicate through a public T1 network as shown in *Figure 17*. Available from a variety of providers, a public T1 network differs from the dedicated T1 circuit in that it is shared by many users.

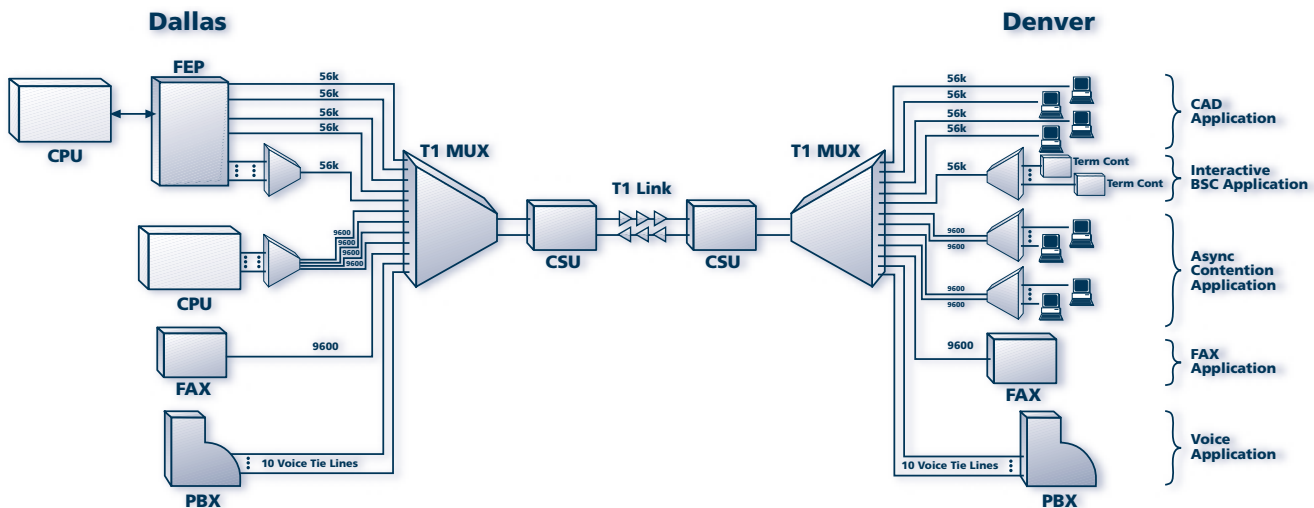

Figure 16:
A simple T1 circuit

Equipment	Description
Channel Bank	A simple device typically used in T1 voice applications. Converts analog voice to digital code (i.e., PCM) and combines 24 such calls on a single DS1 signal (i.e., TDM). "Unbuilds" (demultiplexes) the DS1 signal and returns the voice signal to its original analog state at the receiving end.
T1 Multiplexer	Sophisticated termination equipment used in both voice and data applications. In addition to performing the functions associated with the channel bank, the T1 multiplexer also offers opportunities for network and bandwidth management. Network Management: A company allocates more individual lines to its phone system during peak calling hours and later reassigns the capacity to its computer system for file transfers. Bandwidth Management: A company customizes T1 bandwidth to allocate a single 768 kbps timeslot for video conferencing. The remaining 768 kbps is divided into 12 64 kbps timeslots for standard voice and data transmission. Total: 1.544 Mbps (1.536 kbps plus 8 kbps for framing and signaling).

Table 5:
T1 circuit equipment

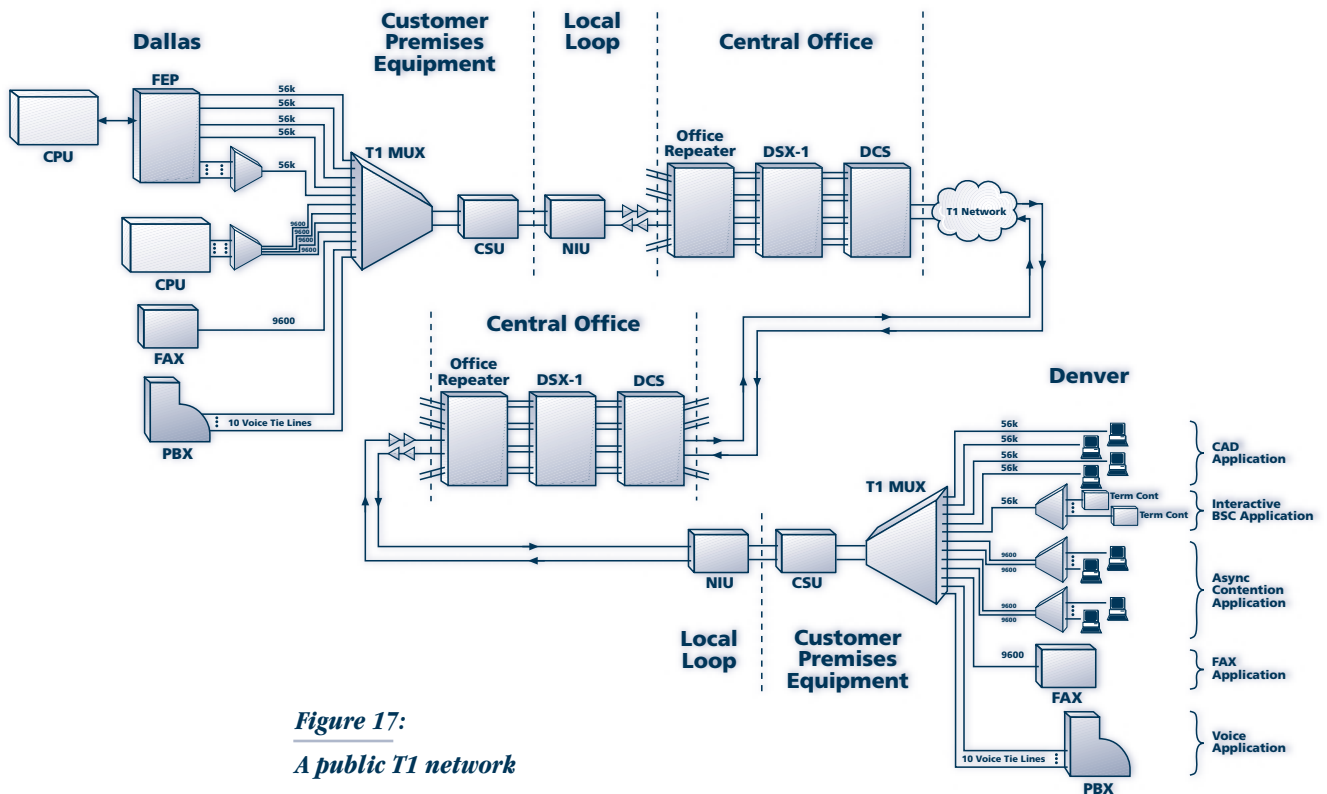

Figure 17:
A public T1 network

In the switched T1 network, equipment is divided into categories based on location: the customer premise (CPE), the local loop, and the central office (CO) equipment. The local loop and CO equipment are described in **Table 6**.

CPE is so named simply because the organization connected to the public T1 network (e.g., a hospital or corporation) is responsible for it. As the responsible party, the organization must ensure that its equipment provides a healthy DS1 signal to the public T1 network. The equipment on the customer premise typically consists of a T1 multiplexer and a CSU (i.e., terminating and user interface equipment, respectively). Both operate exactly as they do in the dedicated T1 circuit.

Local loop equipment essentially serves to connect the customer with the CO. The local loop is also where the telephone company assumes responsibility for the switched T1 network.

CO equipment connects the DS1 signals of many customers and routes traffic through the T1 network based on final destination. This type of equipment can also serve as a test access point for various DS1 signal requirements. Examples of switching equipment are digital cross-connect systems (DCS) and digital signal cross-connect patch panels (DSX).

T1 Testing

Whether public or private, T1 circuits and network equipment must be properly tested and maintained to perform to maximum efficiency. Accordingly, all T1 testing falls under one of two prescribed categories: out-of-service testing and in-service monitoring.

Out-of-Service Testing

Out-of-service testing is so named because live traffic must be removed from the T1 link before testing can begin. In its place, a test instrument transmits a specific data pattern to a receiving test instrument that “knows” the sequence of the pattern being sent. Any deviations from the transmitted pattern are then counted as errors by the receiving instrument.

Out-of-service testing can be conducted on a point-to-point basis or by creating a loopback. Point-to-point testing is a general practice, and requires two test instruments (one at either end of the T1 link, as shown in **Figure 18**).

By simultaneously generating a test data pattern and analyzing the received data for errors, the test instruments can analyze the performance of the link in both directions.

Loopback testing is often used as a “quick check” of circuit performance or when isolating faulty equipment. **Figure 19** shows how loopback testing works.

In loopback testing, a single test instrument sends a loop-up code to the far-end CSU before data is actually transmitted. The loop-up code causes all transmitted data to be looped back toward the test instrument. By analyzing the received data for errors, the test instrument measures the performance of the link up to and including the far-end CSU.

Because loopback testing only requires a single test instrument (and, thus, only one operator), it is very convenient. However, loopback testing is limited in that it can only analyze the combined performance of both directions of the link. As such, it is extremely difficult to determine whether errors are originating on the transmit or the receive side of the T1 link at any given time.

As out-of-service methods, both point-to-point and loopback tests allow detailed measurements of any T1 link. However, since all out-of-service testing requires that live, revenue-generating traffic be interrupted, it is impractical for long-term testing. Thus, this type of testing is typically performed when a circuit is initially installed or when errors are discovered when monitoring live data.

Equipment	Description
Local Loop	
Network Interface Unit (NIU)	The point where customer equipment ends and network equipment begins. Test access facility for network technicians. Also called smart jack.
CO	
Office Repeater	Provides simplex current for all the repeaters on the T1 link. Regenerates the DS1 signal before routing takes place.
DSX	Manual patch panel that primarily serves as a test access point for DS1 signals.
DCS	Electronic switch that “unbuilds” the DS1 and reframes each DS0 based on routing. Also serves as a test access point for DS0 and DS1 signals.

Table 6:
Public T1 network equipment

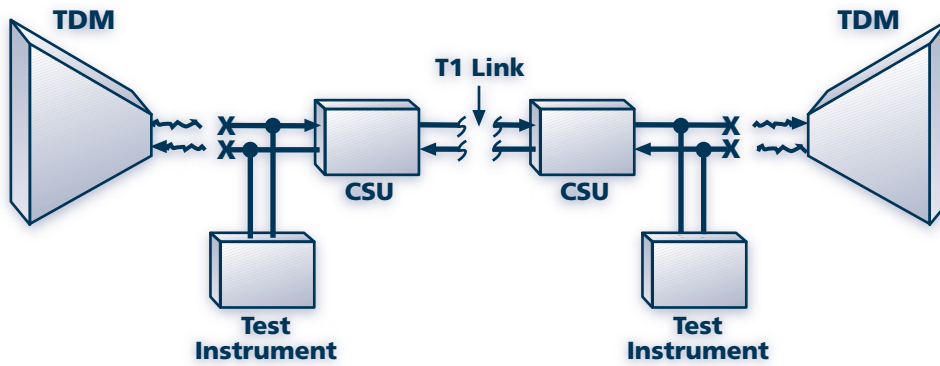

Figure 18:
Point-to-point testing

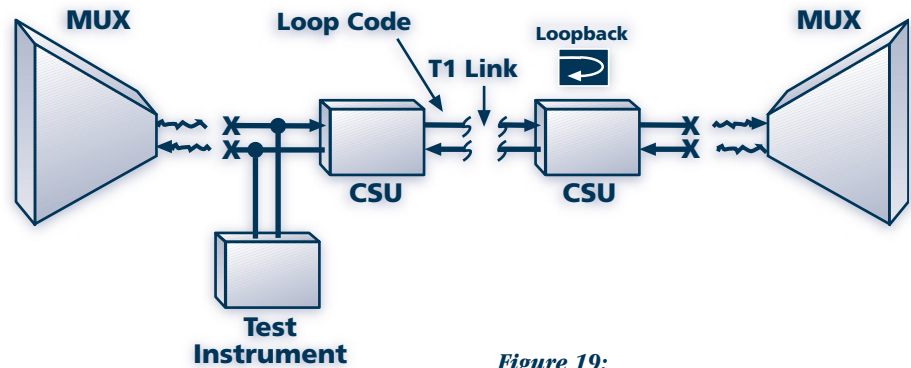

Figure 19:
Loopback testing

In-Service Monitoring of Live Data

The in-service method allows live data to be monitored at various access points without disturbing revenue-generating traffic as shown in **Figure 20**.

Since in-service monitoring does not disrupt the transmission of live traffic, it is more suitable for routine maintenance than out-of-service testing. Additionally, in-service monitoring indicates performance under actual operating conditions. But its primary disadvantage is that its measurements may not be as precise as those available in out-of-service testing. What's more, some network equipment may deter traditional in-service error measuring.

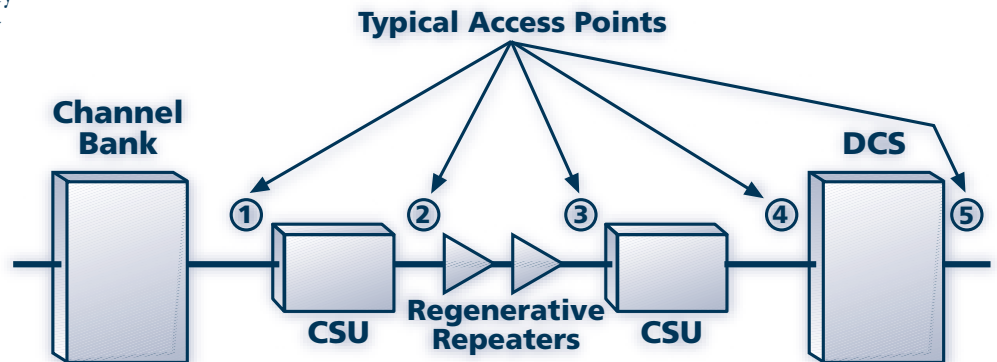

Figure 20:
In-service monitoring

What Can You Measure?

Choosing in-service monitoring or out-of-service testing at any given time often depends on knowing which measurements are available in each method. **Table 7** offers a summary of the basic T1 test measurements and their associated limitations.

Typical Test Scenarios

The measurements described in **Table 7** can be performed in a variety of test scenarios. Here is a brief summary of the four scenarios where T1 testing is typically required.

1. **Installing a T1 link.** When installing a T1 link, out-of-service testing is very useful for verifying equipment operation and point-to-point transmission quality. Start by testing the T1 link independent of other equipment. Then, after establishing the circuit point-to-point, loopback each CSU to ensure that they respond to both loop-up and loop-down codes. Finally add terminating equipment to your test configuration.
2. **Acceptance testing.** When completing installation testing, stress tests and long-term tests should be performed to ensure that the T1 link is operating within relevant specifications. Stress testing is performed by transmitting patterns that simulate minimum ones density and excess zero requirements through T1 equipment and monitoring the output for errors. Long-term testing detects time-related or intermittent errors using data patterns which simulate live data. (One such pattern, the quasi-random signal source (QRSS) is designed specifically for this purpose). It is recommended that long-term testing be performed over a 24- or 48-hour period.
3. **Routine preventive maintenance.** Once the T1 circuit is installed, routine maintenance can indicate degrading service before it disrupts normal operation. Preventive maintenance is usually performed in-service, and involves monitoring live data for BPVs, frame errors, and CRC errors. These tests should also be performed over a 24- or 48-hour period to detect time-specific or intermittent errors.
4. **Fault isolation.** Fault isolation is required once excessive error rates have disrupted service. In-service monitoring is recommended to localize problems and minimize circuit downtime. By monitoring the circuit at various points, you can analyze the results and discover where problems are originating. By performing standard out-of-service tests (i.e., loopback and point-to-point tests), technicians can identify the problem, isolate the faulty equipment, and verify proper operation once the problem is solved.

Measurement	Description	Available	Prime Advantage	Prime Disadvantage
Bit Errors	The basic performance evaluator; counts the number of logic errors in the bit stream (i.e., zeros that should be ones and vice versa). Provides specific error measurements.	Out-of-service only.	Truest measure of point-to-point circuit performance. Permits stress testing to ensure that T1 circuits and equipment are operating within applicable standards.	Live traffic must be removed to allow transmission of a known data pattern.
BPVs	A measure of the number of times pulses of the same consecutive polarity were transmitted across the T1 circuit, in violation of the bipolar signal format. Provides approximate bit error rate.	In-service or out-of-service.	Good indicator of circuit or repeater problem. Can be measured without disrupting live traffic.	Some network equipment corrects BPVs, making them useful only when testing metallic sections of a T1 circuit. Satellite, fiber optic, and microwave correct the bipolar format – only meaningful for metallic media.
Frame Errors	Measures the number of times an incorrect value appears in a bit position reserved for framing (i.e., 193rd bit). Provides approximate bit error rate.	In-service or out-of-service.	When monitored for a long period, can approximate actual bit error rate on an in-service basis.	Only evaluates overhead (not data) bits. Thus, analysis only takes place on every 193rd bit. Frame errors are often corrected by DCS and multiplexers; thus, frame errors are not good indicators of end-to-end performance in networks where this equipment is installed.
CRC Errors	Detects one or more bit errors in a block of data.	In-service or out-of-service.	Very accurate in-service error analysis. Detects bit errors at a 98.4% rate of accuracy.	Only available with ESF framing. DCS and other network equipment may recalculate the CRC.

Table 7:
Basic test measurements

Appendix A:

T1 Transmission Media

This section describes the characteristics of a wide variety of T1 transmission media in detail.

Media Type	Description	Often Used In	Prime Advantage	Prime Disadvantage
Twisted Pair Cable	Wood-pulp or plastic insulated wires twisted together into pairs. Repeaters: Normally required at 6,000-ft. intervals.	Short-haul networks by loop and exchange carriers.	Low cost, easy installation.	Narrow bandwidth, prone to crosstalk.
Coaxial Cable	One or more center conductors surrounded by flexible braid or semi-rigid copper or aluminum tube. Repeaters: Normally required at 40-mile intervals.	Intercity routes in long-haul networks, areas of heavy traffic.	Large bandwidth for high-speed data or video, good noise immunity.	High installation costs, cable is expensive and must be placed carefully.
Microwave Radio	Free-space transmission between ground stations. A line-of-sight transmission path is used, eliminating the need for a physical transmission medium. Stations: Typically placed at 20-30 mile intervals.	Medium-haul terrestrial transmissions.	Inexpensive, bridges areas where right-of-way is expensive to obtain, very high capacity, low error rate.	Signal weakens when weather interferes with line of sight, problems with fading due to reflecting signals.
Fiber Optic Cable	Ribbon cable consisting of one to 12 flat ribbons, with each ribbon containing 12 glass fibers. Repeaters: Although practical at 30-mile intervals, some systems space repeaters at 100-mile intervals.	Medium-and large-capacity interoffice trunks, long-haul intercity routes, video hookups, transoceanic cable systems.	Very high capacity, low attenuation, very good noise immunity, small size, lightweight, easy equipment connection.	Difficulty in obtaining right-of-way access, reliability affected by inability to predict cable cuts, high installation costs.
Satellite	Free-space transmission from ground station to a communications satellite and back to earth. Repeaters: One per satellite system.	Transmitting data at very long distances.	Transmission cost independent of distance, ability to send large amounts of data anywhere.	Distance between earth and satellite produces long delays which can impair voice and seriously damage data transmission.

Table 8:

T1 transmission media

References

Bellamy, John C., *Digital Telephony*, John Wiley and Sons, 1982.

Flanagan, William A., *The Teleconnect Guide to T1 Networking*, Telecom Library, 1986.

Gawdun, M., "The T1 Transmission Media," *Telecommunications*, April 1987.

Green, James Harry, *The Dow Jones-Irwin Handbook of Telecommunications*, Dow Jones-Irwin, 1986.

Leben, Joe, and Martin, James, *Data Communications Technology*, Prentice-Hall, 1988.

Minoli, Dan, *An Overview of T-Carrier Concepts*, Datapro Research Corporation, 1988.

NOTE: Specifications, terms, and conditions are subject to change without notice.

© Copyright 2001 Acterna, LLC. All rights reserved. Acterna, The Keepers of Communications, and its logo are trademarks of Acterna, LLC. All other trademarks and registered trademarks are the property of their respective owners.

Global Headquarters

20400 Observation Drive
Germantown, Maryland 20876-4023 USA
Toll Free 1-800-638-2049 • Tel +1-301-353-1550 • Fax +1-301-444-8468
www.acterna.com

Regional Sales Headquarters

North America

20400 Observation Drive
Germantown, Maryland 20876-4023
USA
Toll Free 1 800 638 2049
Tel +1 301 353 1550
Fax +1 301 444 8468

Latin America

Av. Eng. Luis Carlos Berrini,
936 8/9. Andar
04571-000 Sao Paulo, SP
Brazil
Tel +55 11 5503 3800
Fax +55 11 5505 1598

Asia Pacific

42 Clarendon Street
PO Box 141
South Melbourne, Victoria 3205
Australia
Tel +61 3 9690 6700
Fax +61 3 9690 6750

Western Europe

Arbachtalstrasse 6
72800 Eningen u.A.
Germany
Tel +49 7121 86 2222
Fax +49 7121 86 1222

Eastern Europe, Middle East & Africa

Elisabethstrasse 36
PO Box 13
2500 Baden
Austria
Tel +43 2252 85 521 0
Fax +43 2252 80 727

1st Neopalimovskiy Per. 15/7 (4th floor)
119121 Moscow
Russia
Tel +7 095 248 2508
Fax +7 095 248 4189

Acterna is present in more than 80 countries.
To find your local sales office, go to www.acterna.com

